

 +  **ALL-IN-ONE  
SOUND AND LIGHT SYSTEM**

Rail Brochure

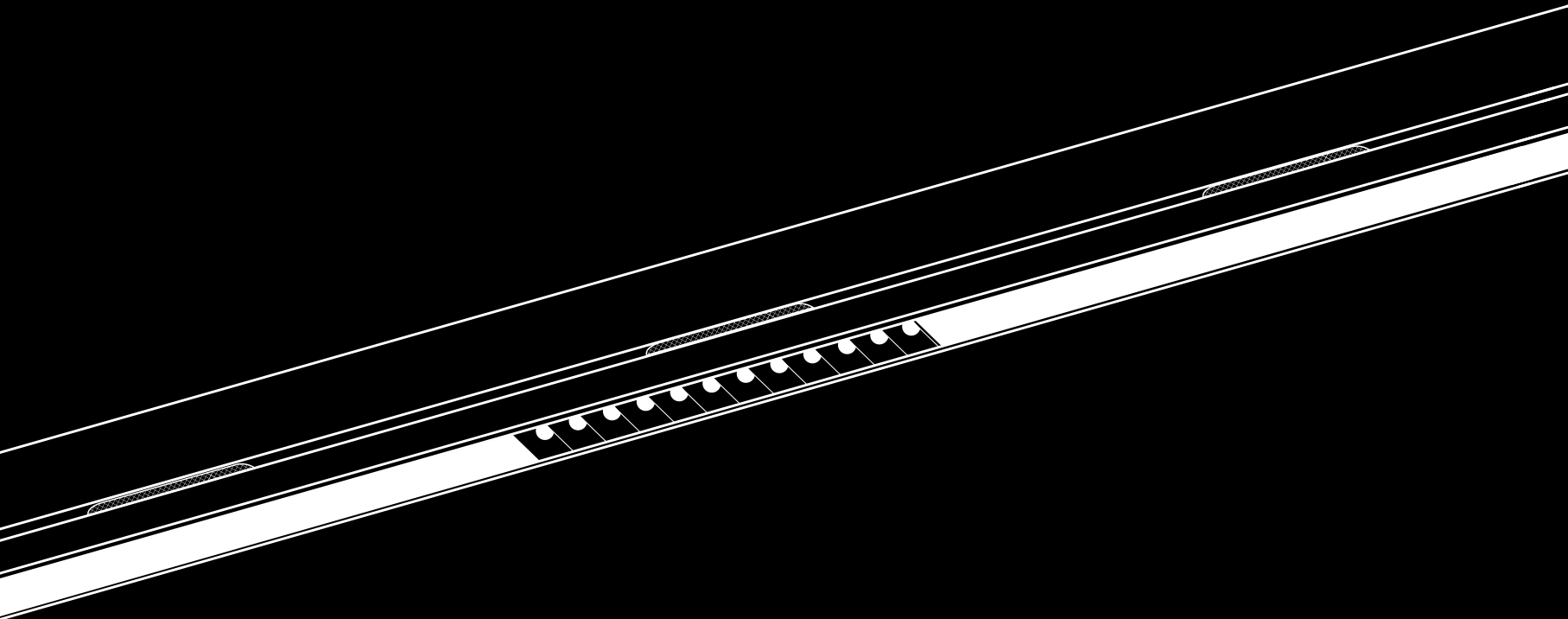

# Immerse yourself in a new expression of **SOUND** and **LIGHT**

Founded over 30 years ago in Tuscany, K-array has become known for its slim, compact professional audio solutions that hide discreetly within architecture and provide exceptional sound quality for every application.

KSCAPE is an extension of K-array's heritage, dedicated to extended the possibilities of sound and putting people at the heart of design by merging technologies such as light and sound for a more immersive human centric experience to improve our connection with buildings and interiors for the everyday use.

**KSCAPE**  
Merging Senses

**Alessandro Tatini**

President K-ARRAY

“

Sound and Light involve our most important senses yet their quality directly affects the quality of our life in ways you could never imagine so when approaching both sound and light as separate chapters of a Project, you often lead to some limits and compromises that negatively affect the final result. Considering all this, the idea that one device can resolve the perfect integration of the two disciplines that sees them perfectly harmonized in unison. It is an integration that offers an important tool for modern design, which simplifies construction and any future maintenance. An innovative and original way to offer quality to our emotions.

**Massimo Ferrati**

CFO - Finance President

“

Passion is the engine that drives our decisions and creates wonderful, rather unexpected paths. It is thanks to this passion that all our products are born with the desire to always create something new and extraordinary. In this work we must always be attentive to what surrounds us, to study the needs of users and sometimes to anticipate them. The KSCAPE brand was born from the desire to be pioneers of the times and to create a product that meets all the needs of human centric design and to elevate those experiences. It is the story of the perfect fusion of what most characterizes us, namely the passion for audio and soundscape, the physical elements and the magical, intangible capability of filling and shaping the space around us. KSCAPE is emotion.

rail

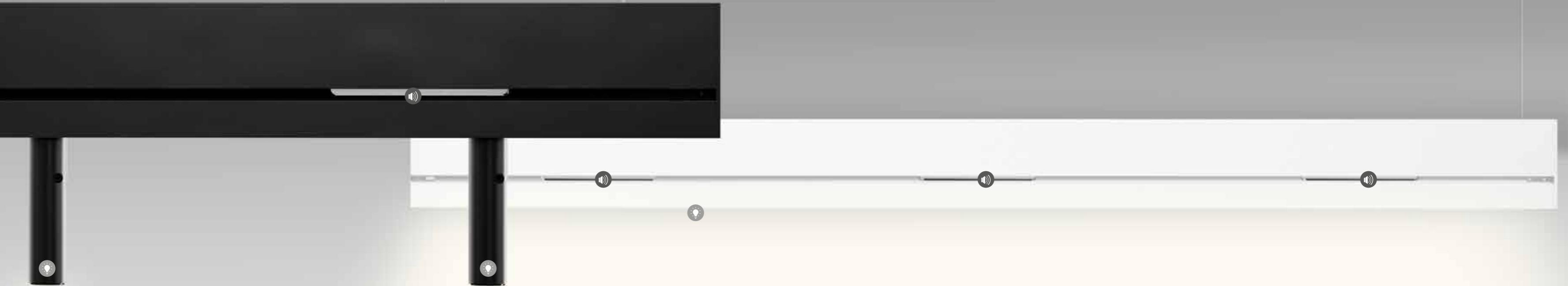

The RAIL system was born to create the most effective, elegant **pro audio solution** with a comfortable **high quality light** that can solve new challenges designers and architects face and light are both essential to the project.

rail

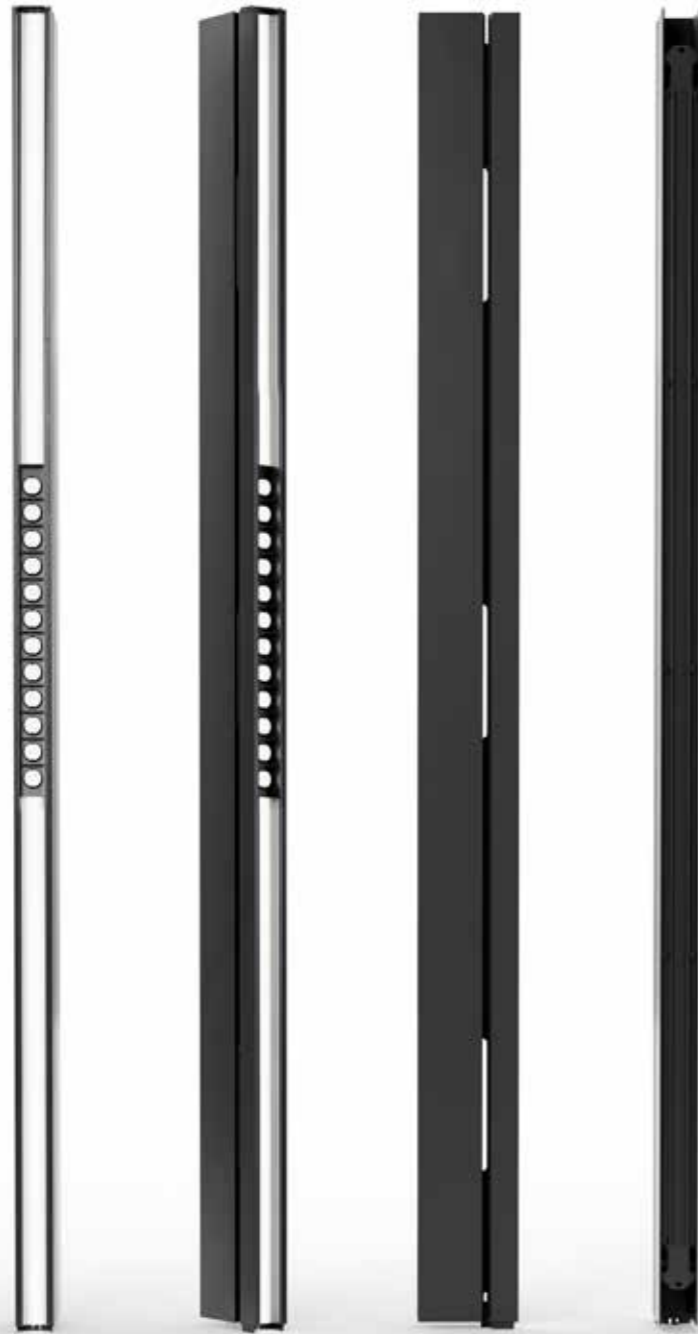

### **Dynamic Pro Audio**

RAIL features 3 full-range cone drivers by K-array built to provide a powerful blend of low and high frequencies spread evenly for a high quality continuous sound emission.

### **Pure Lighting Technology**

This streamlined 1.2m product consists of a linear LED, developed in co-operation with LED manufacturer Nichia, combined with an aluminium coated MicroSilver® parabola available in various optic configurations.

This new kind of LED lighting can provide a full color spectrum, with high CRI.

Some of these optics were studied to bring high visual comfort reaching optimum UGR levels.

rail



## OPTIMUM WORKPLACE DESIGN WITH **LIGHT & SOUND**

**KSCAPE**  
Merging Senses

The role of the office has elevated from a humble and functional place of work to a key instrument in winning the best talent and in making employees feel highly valued.

Traditional office areas like the front and back office are blurred. Instead of hiding employees behind walls, the new way is to express transparency by showcasing employees and the working culture of a company. Meeting rooms have also moved to a more prominent area, while changing their purpose to being multifunctional spaces that are adaptable.

The way we integrate sound in a space has changed dramatically and is largely due to technology. The future in our eyes is human centric lighting and sound designs built into the fabric of workplace environments right from the beginning of the project design instead of forcing an expensive and time consuming solution right at the end, especially where sound is desired.

By merging lighting with audio, we can express a unified experience and develop the knowledge of sound benefits right from the start. KSCAPE is our expression of this synergy between light and sound to extend the possibilities of human centric design.

KSCAPE has a variety of solutions to optimise the illumination in the working space to reach the desired UGR and lux levels including a tunable white LED that can be programmed to match the rhythm of the day inside the workplace.



rail



## OPTIMUM WORKPLACE DESIGN WITH **LIGHT & SOUND**

**KSCAPE**  
Merging Senses

“

“We create intelligent, adaptive soundscapes to improve wellbeing and cognitive functioning in offices, hospitals, schools and other buildings.

The worst implication of this historically has been the speakers, as a dozen stories of ceiling speakers is an architect’s worst nightmare!

RAIL is a game-changer, giving us the incredible K-ARRAY sound quality we know and love while rendering the speakers invisible. And as our clients increasingly realise the need for integrating sonic and visual designs into a coherent theme, RAIL’s multi-sensory approach is precisely where the market is heading. We have been thrilled to recommend and see RAIL deployed in our projects with major multinational clients, with more soon to come.”

**Evan Benway**  
Managing Director, Moodsonic



rail

### Uniform continuous sound emission

- Super even coverage
- The perfect soundscape
- 3 x 1" x 5" woofers per module
- Full-range sound emission for BGM
- Possibility to combine with an ultracompact K-array subwoofer

(for more information on subwoofers visit the website: [www.k-array.com/en/products/type/subwoofers](http://www.k-array.com/en/products/type/subwoofers))



11	Vite AUTOFIL	5X6.5	Connettore
12	PCB210000		Guarnizione tappo superiore 5x2
13	MSCBSM-M3-2-19		Guarnizione tappo superiore 10x2
14	VTM03X06BTINO		Viti autorilettanti
15	MCP095D13_01		
16	DALI		Spina
17	MCA095D01_01		Vite M3x6 T.8 Torx Iso7045
	MCP095D16_01		Nero
	MCP095D14_01		Molla
18	MCP095D15_01		Controllo luci
	MCA095D02_01		Assieme guarnizione
	MCP095D01_01		Guarnizione con





“

“We worked together with KSCAPE to find a way to reduce the technology on the ceiling, therefore minimising aesthetic distractions while providing the technology required to deliver an optimum video conferencing and soundscape performance in the working environment.”

**Elvin Foo**  
Project Manager for JLL Capita Spring Project  
Principle One

Would love to add this quote in somewhere? Maybe on another image of JLL.  
What we have built in CapitaSpring is the next generation office space

**Chris Archibold**  
Country Head  
JLL Singapore



rail

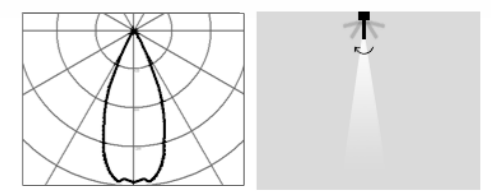



rail

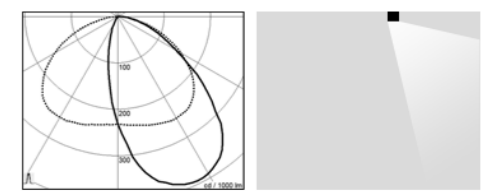





“

“The natural light in Montauk was our inspiration for the lighting system – it is really what makes this area so special and what we aspired to capture but, in a traditional barn, the goal was to achieve a solution that was versatile and could be tailored to the needs of the wide variety of artwork we will exhibit. K-array provided us with extreme latitude in adjusting the lights for the changing demands of the lighting conditions each unique body of work requires.”

Furthermore “The lighting is, of course, critical in allowing a work of art to shine and exemplify the small surface details that might be hard to see. One thing I was struck by was the way that the lights brought out elements of paintings I’m extremely familiar with but had not seen under other conditions.”

**Max Levai**

Forbes “One To Watch” Art Dealer

rail

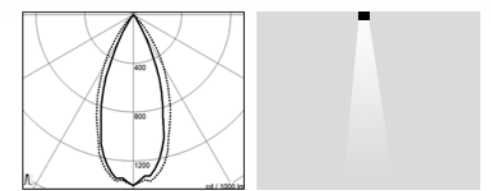





### Benefits of scale

A simulation of RAIL (when compared to a scalable solution of ceiling speakers and separate comparable light fixtures) has proven significant savings on wiring, shipping, labor, product costs and has proven it could be 35% more energy efficient. The combination of audio and light into one high quality solution also means that there is a more streamlined service for project design, installation and maintenance.

25% Less On Product Costs

52% Less For Labour/Wiring Costs



rail

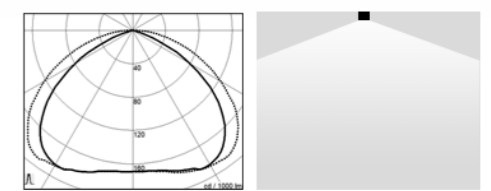



rail



TOM: Can we change to something related to RGBW. The color brochure by Fiorella?

NICO: Can you send me the brochure file?

rail

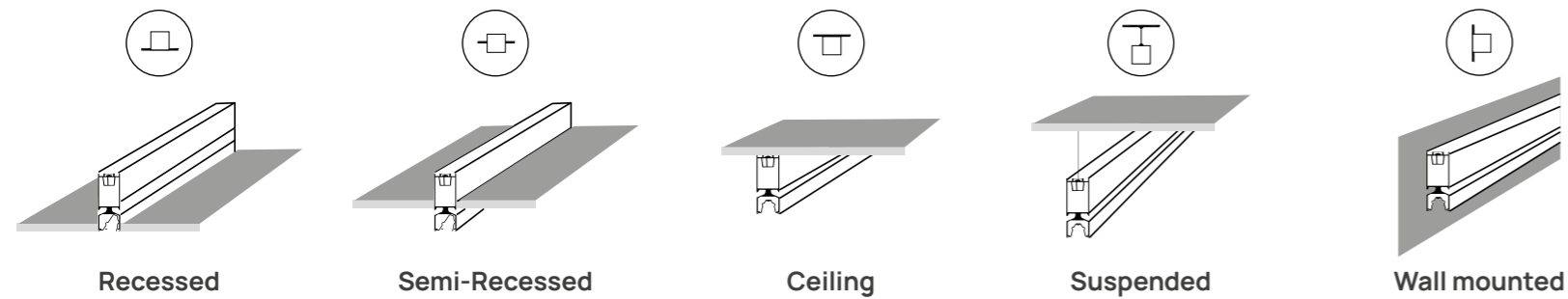

Rail has 4 combinations of different optics: symmetrical, symmetrical + optical spot, asymmetrical, diffused and the possibility of housing a low voltage electrified track with projectors. Multiple installation systems are available to demonstrate the ultimate flexibility of RAIL including: recessed, semi-recessed, ceiling, suspended and applique.

The ceiling, suspended and wall-mounted versions can also provide indirect lighting with a constant color temperature or RGB+W light. Where audio is crucial, all the mounting options guarantee optimal sound diffusion, including the recessed version that provides a small gap on each side of the RAIL which has been designed and studied in detail in order not to compromise the acoustic performance.





rail

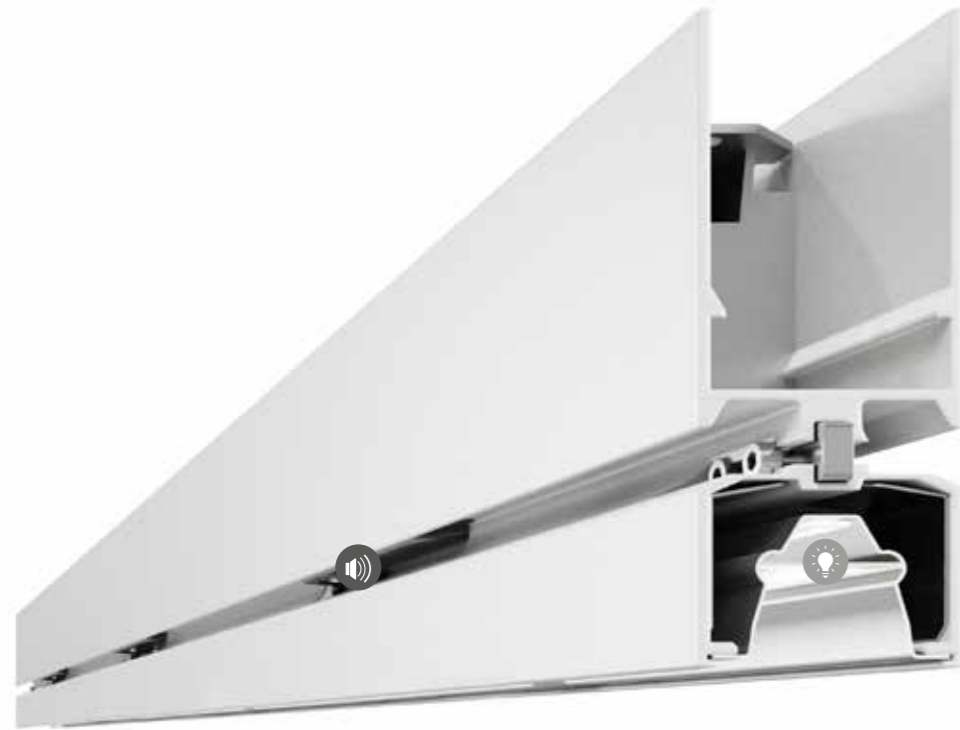
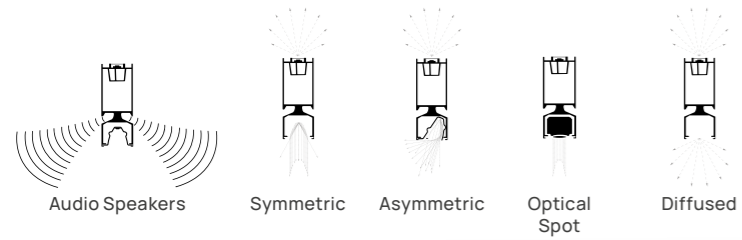

#### LENS

- Proprietary optical system
- Reflector made of Miro Silver Aluminum
- Reflectance > 98%

#### LED PCB characteristics

- PCB made in Italy
- LED spacing: 3.7mm
- LED by Japan manufacturer Nichia
- 33W 3680lm (only for direct light)
- Lm80 \_ 60.000 hours
- Color temperature: 3000K
- CRI (color rendering index) 90
- Indirect light available in 3000K or RGBW
- Tunable White Available needs to be added



#### SPEAKER

##### Transducers:

3 x 1" x 5" neodymium magnet transducers with 0.75" voice coil

##### Frequency response:

60 Hz-20Hz (-6 dB) full range preset @ 84dB max SPL  
200Hz-20Hz (-6dB) w/subwoofer preset @ 97dB max SPL

##### Rated power:

75W peak

##### Maximum SPL:

97dB peak with dedicated preset

##### Nominal Impedance:

48Ω

##### Coverage:

V:10° H:110° (unit set in vertical position)

#### CASCADE CONNECTION

LIGHT: max 5 units

AUDIO: max 12 units @ 4Ω

DALI CONTROL:

- Individual control of all RAIL light channels
- Up to 64 channels, 16 groups and 16 scenes per line
- Polarity-free DALI bus
- Status feedback from RAIL channels

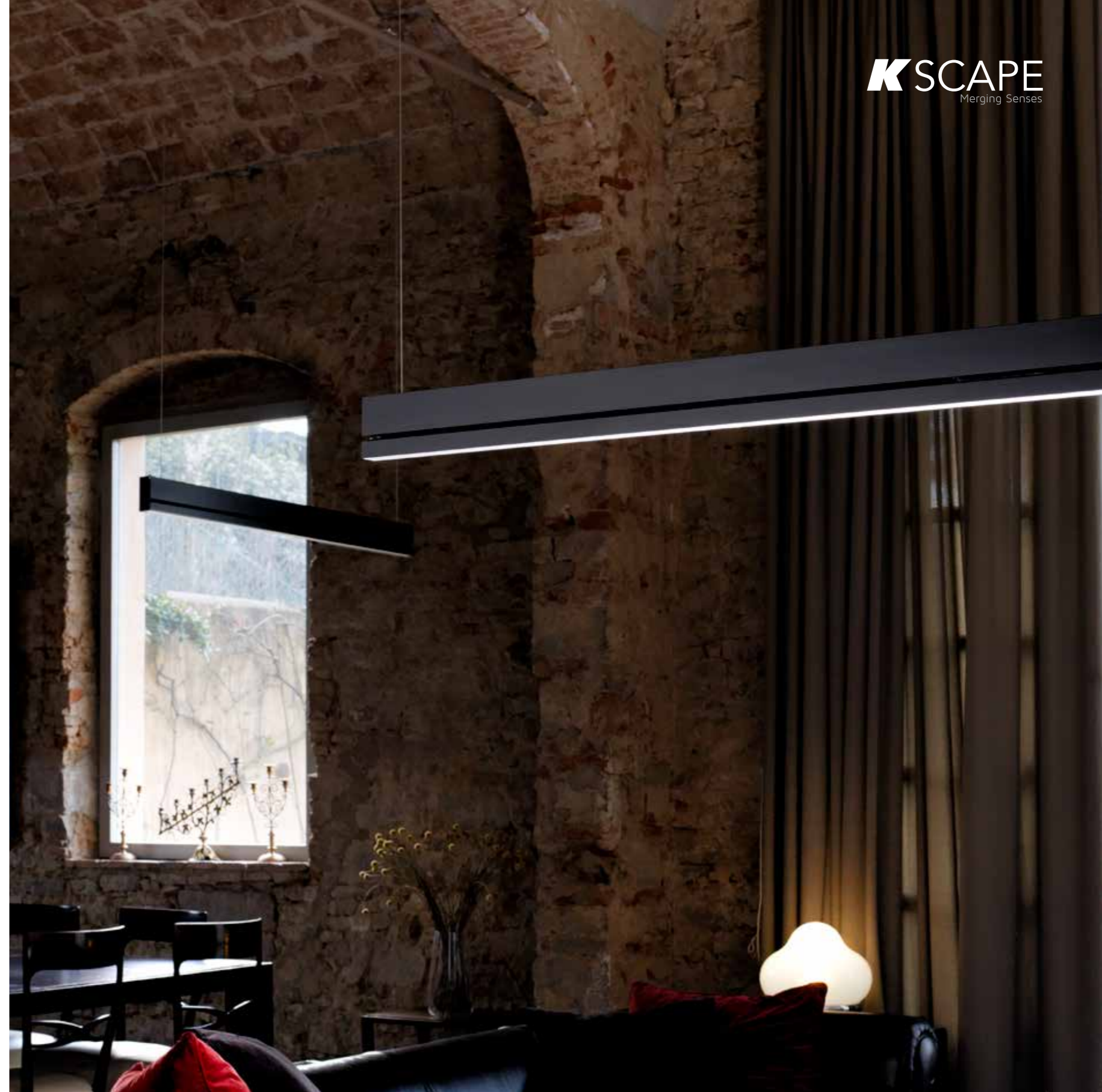



rail



#### SPOTLIGHT

##### LED CHARACTERISTICS

- LED Nichia
- Led flux 501lm
- Color temperature: 3000K
- CRI (color rendering index) 90
- Input voltage 24Vdc
- Adjustment:  
from 0 to 90° on the vertical plane  
355° on the horizontal plane



#### SPEAKER

##### Transducers:

3 x 1" x 5" neodymium magnet transducers with 0.75" voice coil

##### Frequency response:

60 Hz-20Hz (-6 dB) full range preset @ 84dB max SPL  
200Hz-20Hz (-6dB) w/subwoofer preset @ 97dB max SPL

##### Rated power:

75W peak

##### Maximum SPL:

97dB peak with dedicated preset

##### Nominal Impedance:

48Ω

##### Coverage:

V:10° H:110° (unit set in vertical position)

#### ELECTRIFIED TRACK

- Standard Stucchi electrified track
- Magnetic adapter for easy mounting
- Input voltage 24Vdc

#### CASCADE CONNECTION

LIGHT: max 5 units

AUDIO: max 12 units @ 4Ω

DALI CONTROL:

- Individual control of all RAIL light channels
- Up to 64 channels, 16 groups and 16 scenes per line
- Polarity-free DALI bus
- Status feedback from RAIL channels

**KSCAPE**  
Merging Senses





SYMMETRIC OPTIC

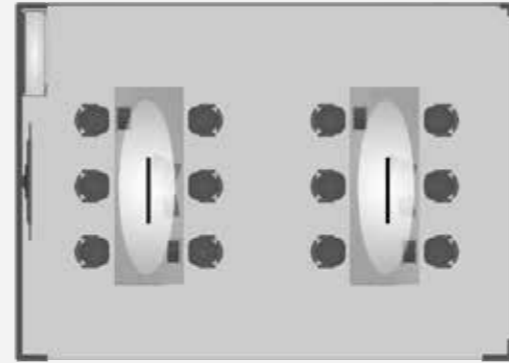

The symmetrical optic has a blade emission, therefore along the C0 plane it is very narrow, while on the C90 plane it has a wider opening. It is the perfect option for workplaces thanks to the UGR <math><19</math> along the C0 plane that illuminates the space lengthwise in a homogeneous and uniform manner.



OPTICAL SPOT + SYMMETRIC OPTIC

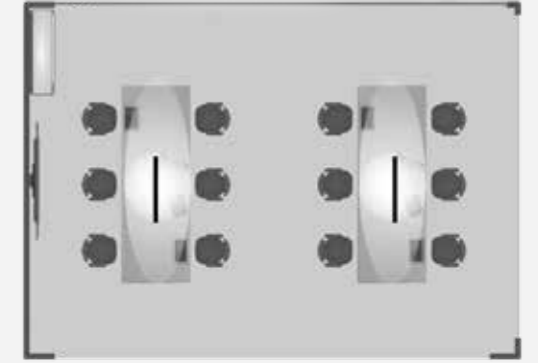
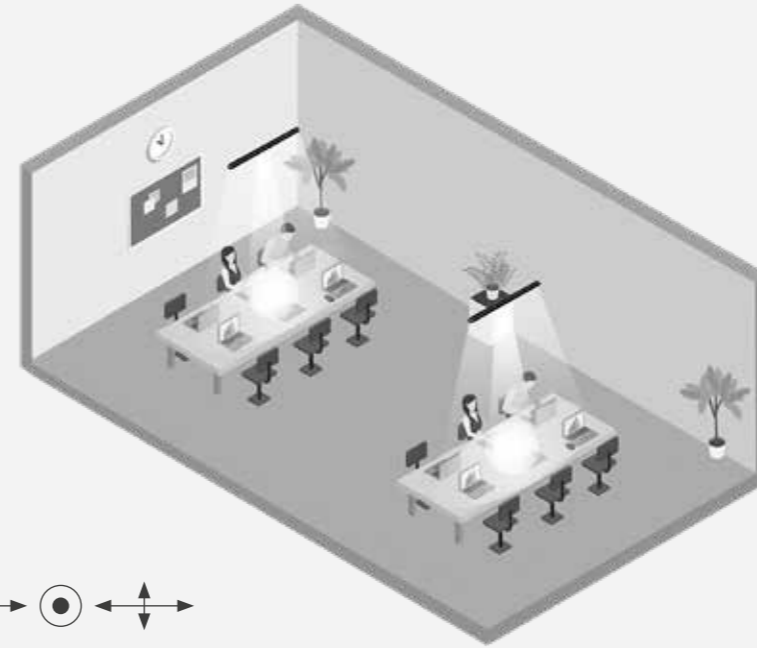

The symmetrical optical + optical spot combination is the best proposal for environments that require a controlled UGR. The optical spot has a particular eyelet structure and a highly concentrated light beam with UGR <math><19</math>



DIFFUSED OPTIC

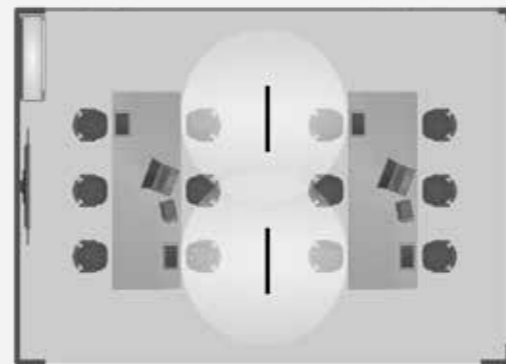

Thanks to the very wide beam angle, on both planes C0 and C90, the diffused optic is widely used in environments that require soft and uniform light, without particular focus, such as corridors, waiting rooms, waiting areas, etc.



ASYMMETRIC OPTIC

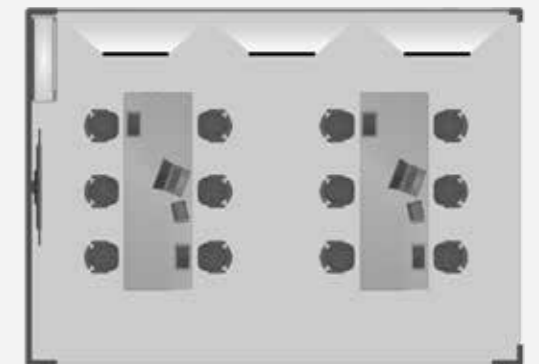
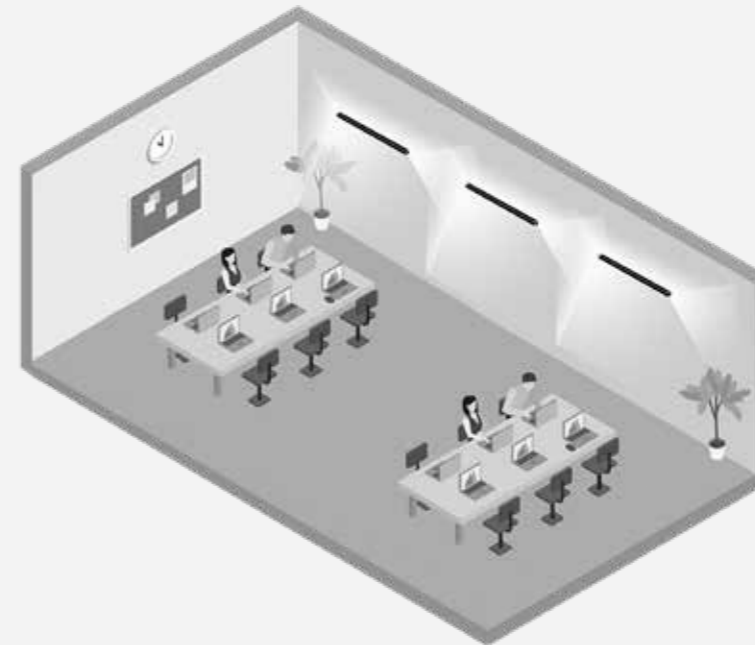

The asymmetrical optic allows you to wash the wall homogeneously. With a standard height of 3m, the recommended distance for good wall lighting is 1m, while the recommended distance between the products is 1.2m



PROJECTOR 15° OPTIC

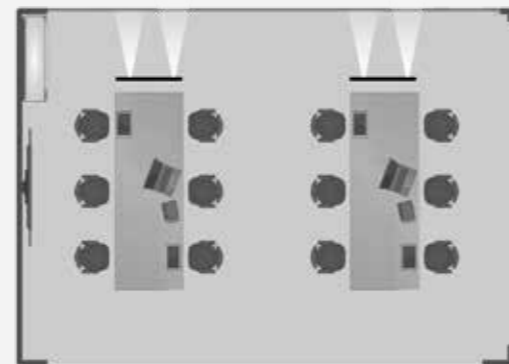

Flexibility is the key that identifies any projector. Thanks to the possibility of orienting them by 90° on the vertical plane and 355° on the horizontal one, the projectors can be used in a wide variety of environments, adapting perfectly to match the lighting design required. In addition to the standard 45° optic, 15° and 25° are also available to order.



INDIRECT OPTIC

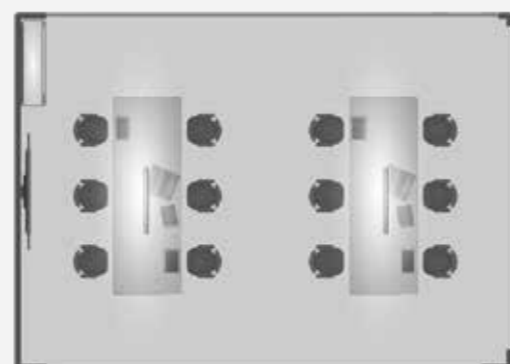









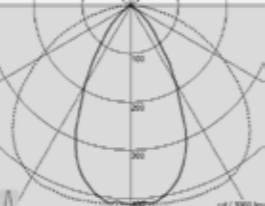

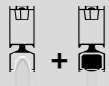
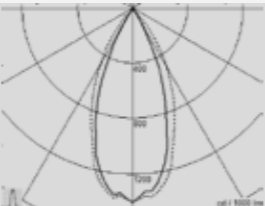
The indirect option completes the range of optics. This perspective gives breadth to the rooms and gives them an architectural connotation if placed within spaces with high-quality ceilings and significant heights. Available with constant temperature 3K and even RGBW

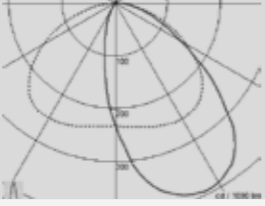

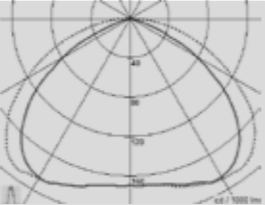

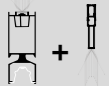
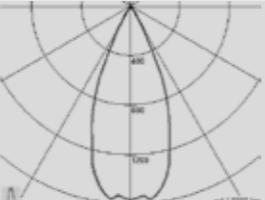
SUMMARY OF THE CONFIGURATIONS

OPTICS	DIMMING CONTROL	LIGHTING OPTIONS	MOUNTING OPTIONS	PHOTOMETRIC DATA	FINISHES	AUDIO COMBINATIONS	DATASHEET
<b>SYMMETRIC</b> 	24V	<input type="checkbox"/> Direct only (tunable white)	Suspended Recessed Semi-recessed Ceiling		Black White Custom RAL	<input type="checkbox"/> <input type="checkbox"/> Audio <input type="checkbox"/> Non Audio	
	DALI	<input type="checkbox"/> Direct <input type="checkbox"/> Indirect (Available in RGBW)	Suspended Wall mounted			<input type="checkbox"/> <input type="checkbox"/> Audio <input type="checkbox"/> Non Audio	
<b>SYMMETRIC + OPTICAL SPOT</b> UGR <19 	DALI	<input type="checkbox"/> Direct only (tunable white)	Suspended Recessed Semi-recessed Ceiling		Black White Custom RAL	<input type="checkbox"/> <input type="checkbox"/> Audio <input type="checkbox"/> Non Audio	
		<input type="checkbox"/> Direct <input type="checkbox"/> Indirect (Available in RGBW)	Suspended			<input type="checkbox"/> <input type="checkbox"/> Audio <input type="checkbox"/> Non Audio	
<b>ASYMMETRIC</b> 	24V	<input type="checkbox"/> Direct only (tunable white)	Suspended Recessed Semi-recessed Ceiling		Black White Custom RAL	<input type="checkbox"/> <input type="checkbox"/> Audio <input type="checkbox"/> Non Audio	
	DALI	<input type="checkbox"/> Direct <input type="checkbox"/> Indirect (Available in RGBW)	Suspended Wall mounted			<input type="checkbox"/> <input type="checkbox"/> Audio <input type="checkbox"/> Non Audio	
<b>DIFFUSED</b> 	24V	<input type="checkbox"/> Direct only (tunable white)	Suspended Recessed Semi-recessed Ceiling		Black White Custom RAL	<input type="checkbox"/> <input type="checkbox"/> Audio <input type="checkbox"/> Non Audio	
	DALI	<input type="checkbox"/> Direct <input type="checkbox"/> Indirect (Available in RGBW)	Suspended Wall mounted			<input type="checkbox"/> <input type="checkbox"/> Audio <input type="checkbox"/> Non Audio	
<b>ELECTRIFIED TRACK + PROJECTOR</b> 	24V	<input type="checkbox"/> Indirect only (Available in RGBW)	Suspended Recessed Semi-recessed Ceiling		Black White Custom RAL	<input type="checkbox"/> <input type="checkbox"/> Audio <input type="checkbox"/> Non Audio	
	DALI	<input type="checkbox"/> Spot Lights	Suspended			<input type="checkbox"/> <input type="checkbox"/> Audio <input type="checkbox"/> Non Audio	

INDIRECT LIGHT available in 3000K or RGBW

ACCESSORIES

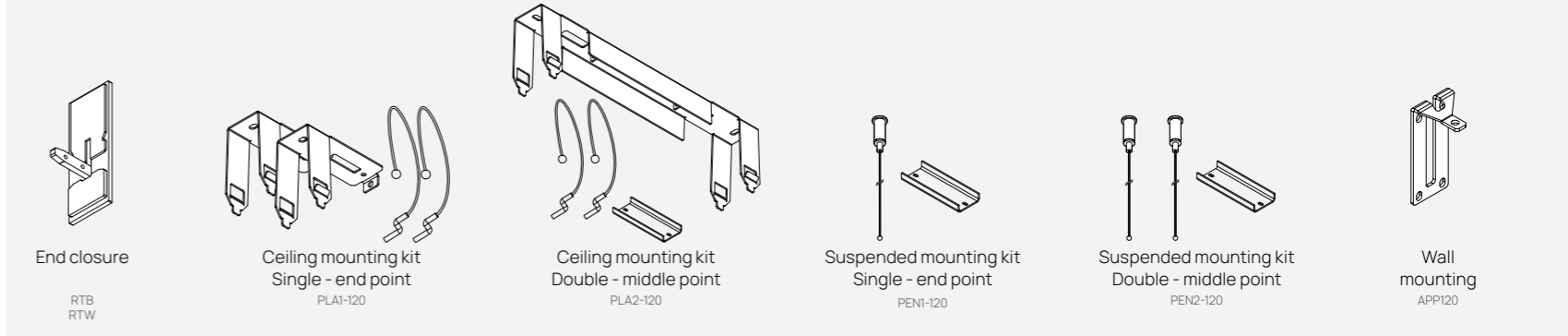

MECHANICAL DRAWINGS

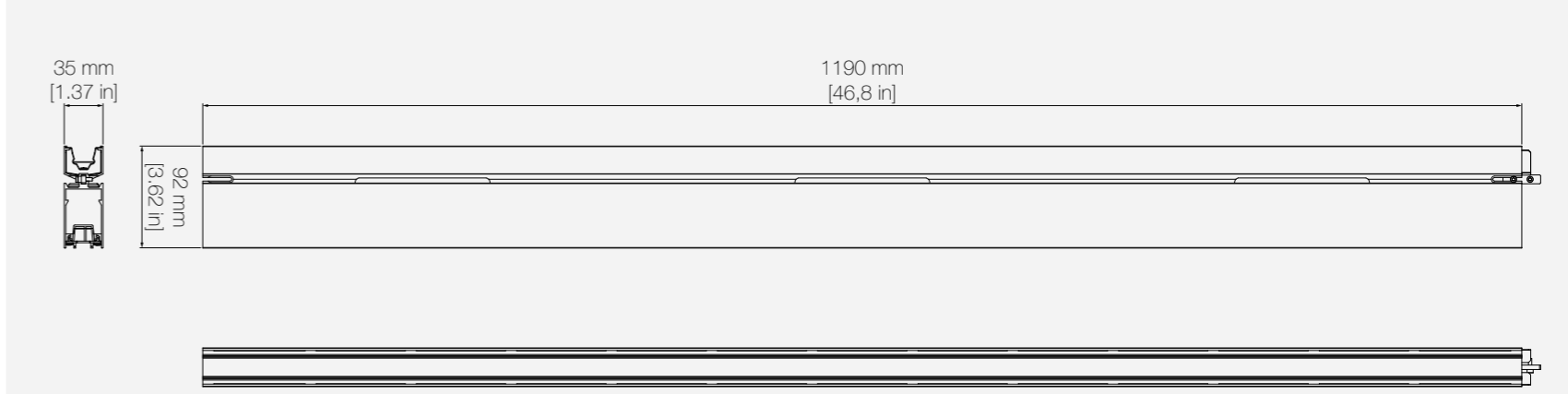

**TOM: Something like new projectors available in 2023**

PROJECTOR

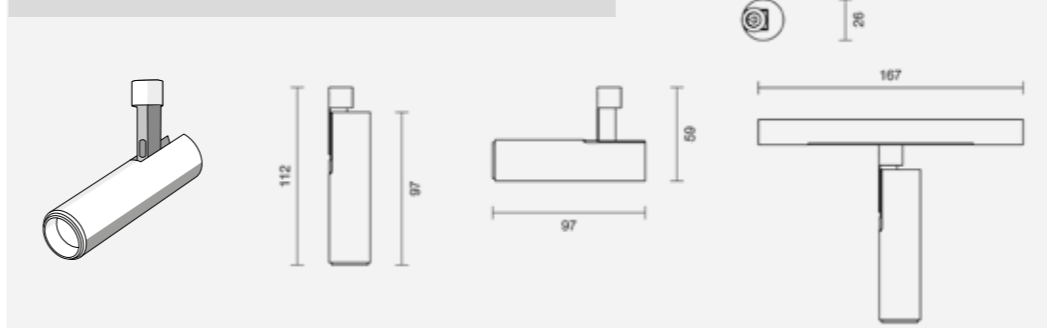

**NICO: I did not understand**

Projector technical specifications

- Color temperature CCT 3000K
- Fixture flux 463lm
- Fixture power 5,9W
- Efficiency: 78lm/W
- Beam Angle 45°
- Color rendering index 90
- Control system Dali
- IP protection IP40
- Input voltage 24Vdc
- Beam angle 15° and 25° available

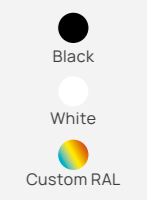

rail

# L and T joint

## Flexibility

Compose RAIL according to your needs with other mounting options including the L-corner and T-shape for a complete system setup.

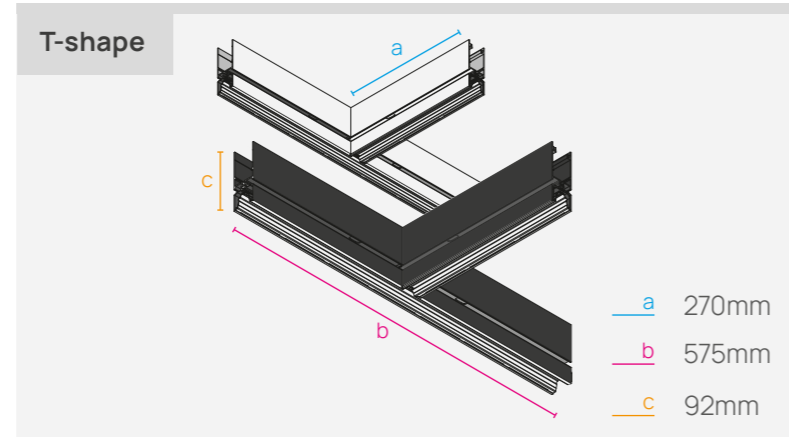
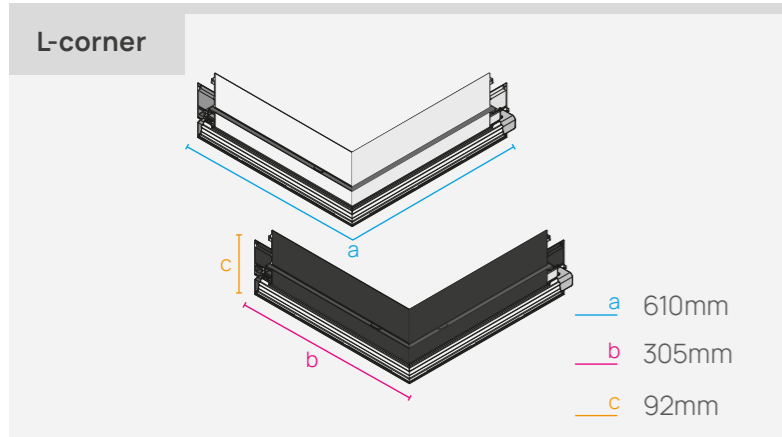

**AVAILABLE COMBINATIONS FOR BOTH**

OPTICS	DIMMING CONTROL	LIGHTING OPTIONS	MOUNTING OPTIONS	PHOTOMETRIC DATA	FINISHES	AUDIO COMBINATIONS	DATASHEET
<b>SYMMETRIC</b> 	24V	<input type="checkbox"/> Direct only (tunable available)	Suspended Recessed Semi-recessed Ceiling		● Black ● White Custom RAL	<input type="checkbox"/> Non Audio	
	DALI						
<b>DIFFUSED</b> 	24V	<input type="checkbox"/> Direct only (tunable available)	Suspended Recessed Semi-recessed Ceiling		● Black ● White Custom RAL	<input type="checkbox"/> Non Audio	
	DALI						





rail



**CUSTOMIZE YOUR RAIL AS YOU NEED**  
In addition to the standard **Black** and **White**,  
**Custom RAL** are also available to order.



43°57'00"N - 11°22'59.88"E  
AN AUTHENTIC PLACE

**KSCAPE**

Via P. Romagnoli 17 | 50038 Scarperia e San Piero - Florence - Italy

ph +39 055 84 87 222

info@kscapemergingsenses.com

www.kscapemergingsenses.com

The data included in this catalog may vary. Consult the website for updated data.

In accordance with its policy of continuous product development, K-array reserves the right to introduce any changes to its products without prior notice. Materials, colors and data presented in the catalog are only for reference. K-array is available to customize systems, finishes and new applications upon request.

All rights reserved © 2022



**K**SCAPE  
Merging Senses

[www.kscapemergingsenses.com](http://www.kscapemergingsenses.com)